

**Coffee System
 Mira Traditional espresso coffee FAP
 machine, 2 group, 10.1 liter boiler, steam
 & water**

ITEM # _____

MODEL # _____

NAME # _____

SIS # _____

AIA # _____

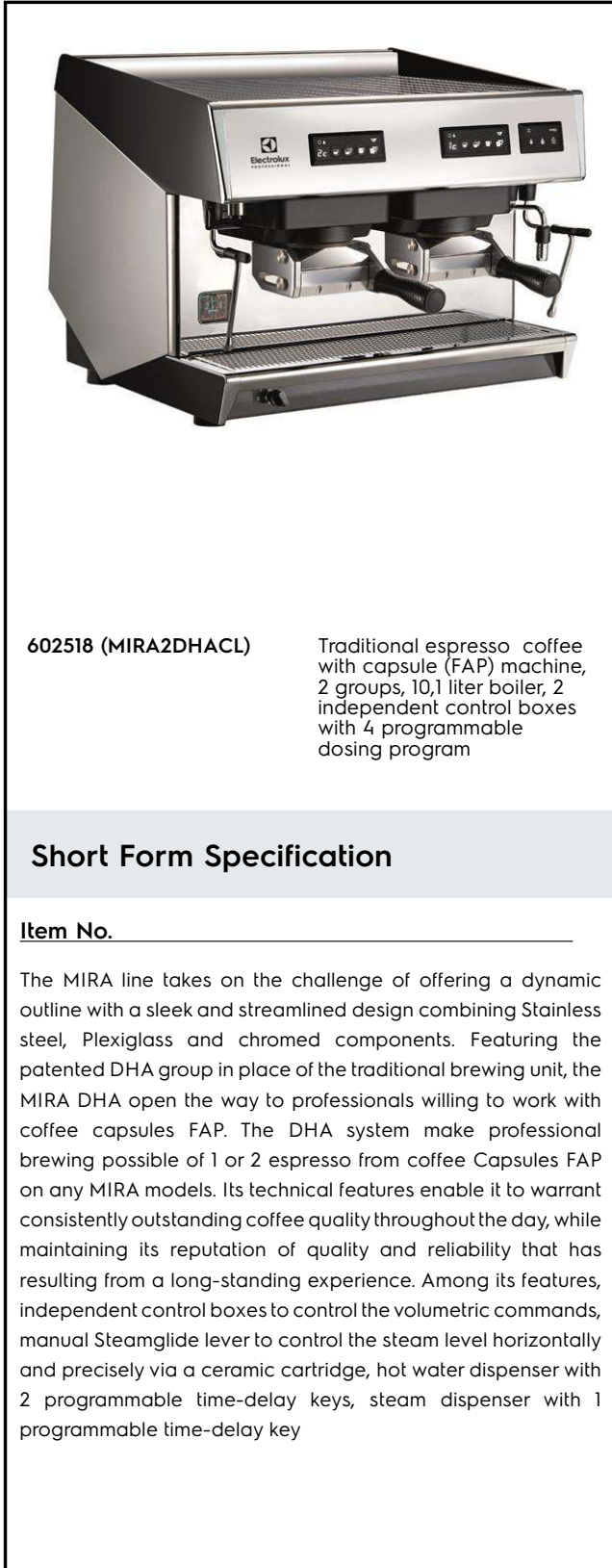
602518 (MIRA2DHACL)

Traditional espresso coffee with capsule (FAP) machine, 2 groups, 10,1 liter boiler, 2 independent control boxes with 4 programmable dosing program

Short Form Specification

Item No. _____

The MIRA line takes on the challenge of offering a dynamic outline with a sleek and streamlined design combining Stainless steel, Plexiglass and chromed components. Featuring the patented DHA group in place of the traditional brewing unit, the MIRA DHA open the way to professionals willing to work with coffee capsules FAP. The DHA system make professional brewing possible of 1 or 2 espresso from coffee Capsules FAP on any MIRA models. Its technical features enable it to warrant consistently outstanding coffee quality throughout the day, while maintaining its reputation of quality and reliability that has resulting from a long-standing experience. Among its features, independent control boxes to control the volumetric commands, manual Steamglide lever to control the steam level horizontally and precisely via a ceramic cartridge, hot water dispenser with 2 programmable time-delay keys, steam dispenser with 1 programmable time-delay key

Main Features

- Automatic cleaning cycle.
- The MIRA line offers a dynamic outline with a sleek and streamlined design combining Stainless steel, Plexiglass and chromed components.
- Featuring the patented DHA group in place of the traditional brewing unit, the MIRA DHA open the way to professionals willing to work with coffee capsules FAP. The DHA system make professional brewing possible of 1 or 2 espresso from coffee Capsules FAP.
- Its technical features enable it to warrant consistently outstanding coffee quality throughout the day: independent control boxes to control the volumetric commands, manual Steamglide lever to control the steam level horizontally and precisely via a ceramic cartridge, hot water dispenser with 2 programmable time-delay keys, steam dispenser with 1 programmable time-delay key.
- Traditional espresso coffee with capsule (FAP) machine.
- 2 independent control boxes with 4 programmable dosing keys.
- Programmable steam and hot water.

Construction

- Stainless steel body.
- Manual Steamglide lever.
- 2 groups - 10.1 liter boiler.

Optional Accessories

- Steam outlet with adjustable flow PNC 871000
- Hot water outlet with adjustable flow PNC 871001
- Knock box drawer for 2-group machines PNC 871006
- Cappuccinatore/foamer device with two positions for hot milk and for foam only for machines without Steamair PNC 871011
- Cappuccino system/auto foam device by air injection for traditional machines only for machines without Steamair PNC 871012
- Teflon steam wand only for machines without Steamair PNC 871013
- Side milk refrigerator 8 liter nominal capacity for up to 4 liter milk containers PNC 871014
- Side milk refrigerator 8 liter nominal capacity for up to 4 liter milk containers with digital display PNC 871015
- Raised feet kit PNC 871041

APPROVAL: _____

**Coffee System
 Mira Traditional espresso coffee FAP machine, 2 group,
 10.1 liter boiler,
 steam & water**

Front

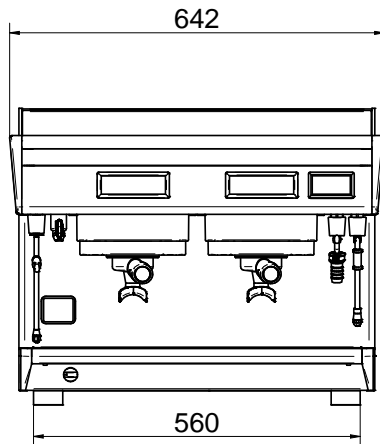

Side

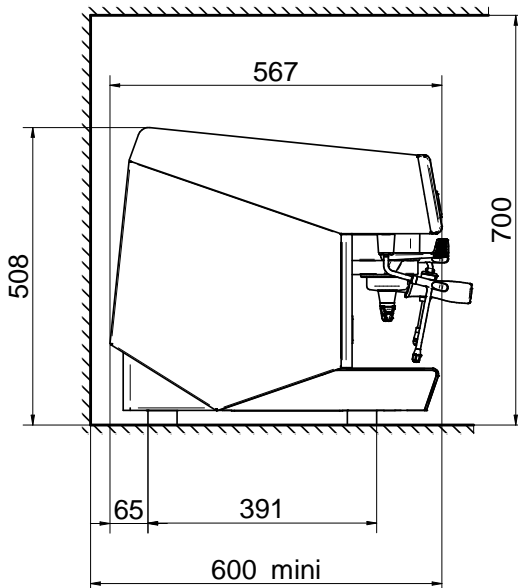

Top

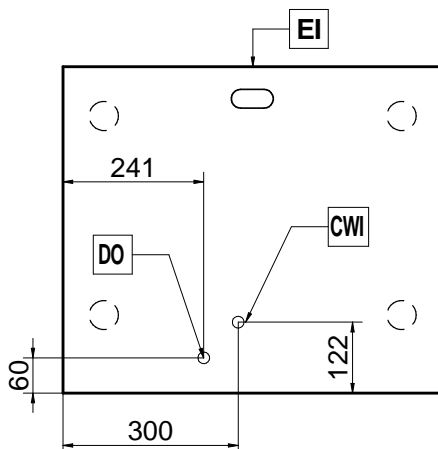
Electric

Supply voltage:	
602518 (MIRA2DHACL)	400 V/3N ph/50 Hz
Electrical power max.:	4.7 kW
Current consumption:	7 Amps
Plug type:	

Water:

Cold water temperature (min/max):	5 / 60 °C
--	-----------

Key Information:

External dimensions, Width:	642 mm
External dimensions, Depth:	570 mm
External dimensions, Height:	510 mm
Net weight:	55 kg
Shipping volume:	0.69 m ³